



|                |      |
|----------------|------|
| CATALOG NUMBER | TYPE |
|                |      |
| PROJECT NAME   | DATE |
|                |      |

## SPECIFICATIONS

### FEATURES

- Thermoplastic exit sign with waterproof polycarbonate shield
- Universal mounting
- Part of Astralite's quick ship program

### CONSTRUCTION

- Durable polycarbonate shield
- UV-stable, impact-resistant thermoplastic housing; meets UL94V-0 flame rating
- EXIT letters are 6" tall with 3/4" stroke; 100 ft viewing distance

### LAMP

- AllnGaP LEDs with a rated life of 10+ years

### ELECTRONICS

- Dual-voltage input capability: 120/277V
- Low-voltage disconnect
- AC indicator light with test switch
- Brownout protection

## DIMENSIONS

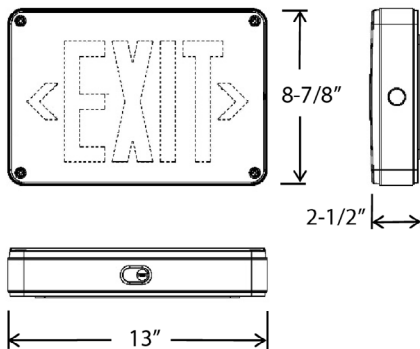

### BATTERY

- EM option comes standard with nickel-cadmium battery
- Provides a minimum of 90 minutes of illumination upon loss of power
- Operating temperature range: 10-40° C

### COMPLIANCE

- Meets or exceeds UL 924, NFPA 101, NEC and OSHA illumination standards

### WARRANTY

- 5-year warranty on housing and electronics. Battery is prorated

## WTP

WATERPROOF EXIT SIGN



| Material      | Mounting  | Battery        | Code Compliance |
|---------------|-----------|----------------|-----------------|
| Thermoplastic | Universal | Nickel-cadmium | UL 924          |

## ORDERING GUIDE

| MODEL                       | MOUNTING              | LETTER COLOR           | HOUSING COLOR            | POWER CONFIGURATION  | OPTION <sup>1</sup>                         |
|-----------------------------|-----------------------|------------------------|--------------------------|----------------------|---------------------------------------------|
| WTP<br>Waterproof Exit Sign | U<br>Universal Option | R<br>Red<br>G<br>Green | W<br>White<br>B<br>Black | EM<br>Battery Backup | SD<br>Self Diagnostics<br>C<br>Cold Weather |

### Notes:

1. Battery Backup Model Only