



CATALOG NUMBER	TYPE
PROJECT NAME	DATE

SPECIFICATIONS

FEATURES

- Thermoplastic emergency light with waterproof polycarbonate shield
- For wall mounting
- Part of Astralite's quick ship program

CONSTRUCTION

- UV stabilized thick polycarbonate shield
- UV-stable, impact-resistant thermoplastic housing; meets UL94V-0 flame rating

LAMP

- Utilizes two high-efficiency 2.5W LED heads in emergency mode with a total lumen output of 660lm

ELECTRONICS

- Dual-voltage input capability: 120/277V
- Low-voltage disconnect
- AC indicator light with test switch
- Brownout protection

BATTERY

- Nickel-cadmium battery is standard and provides a minimum of 90 minutes of illumination in emergency mode
- Operating temperature range: 10-40° C

COMPLIANCE

- Meets or exceeds UL 924, NFPA 101, NEC and OSHA illumination standards

WARRANTY

- 5-year warranty on housing and electronics. Battery is prorated

WEU

WEATHERPROOF EMERGENCY UNIT



DIMENSIONS

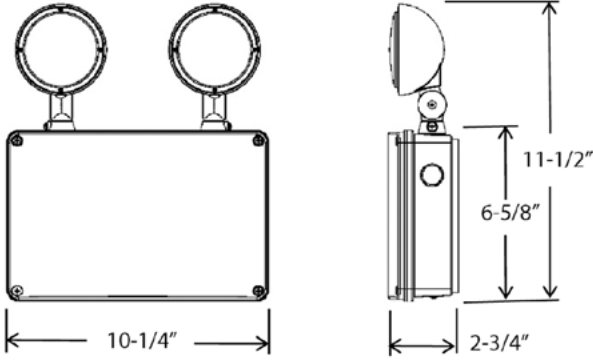

ORDERING GUIDE

MODEL	HOUSING COLOR	FACILITY INSTALLED OPTIONS
WEU	W White B Black	REM Remote Capable SD Self Diagnostics C Cold Weather