



CATALOG NUMBER	TYPE
PROJECT NAME	DATE

SPECIFICATIONS

FEATURES

- EXIT-EM combo with waterproof polycarbonate shield
- Designed for wall and end mounting
- Part of Astralite's quick ship program

CONSTRUCTION

- Durable polycarbonate shield
- UV-stable, impact-resistant thermoplastic housing; meets UL94V-0 flame rating
- EXIT letters are 6" tall with 3/4" stroke; 100ft viewing distance

ILLUMINATION

- AllInGaP LEDs with a rated life of 10+ years

ELECTRONICS

- Dual-voltage input capability: 120/277V
- Low-voltage disconnect
- AC indicator light with test switch
- Brownout protection

BATTERY

- Nickel-cadmium battery is standard and provides a minimum of 90 minutes of illumination upon loss of power
- Operating temperature range: 10-40° C

COMPLIANCE

- Meets or exceeds UL 924, NFPA101, NEC and OSHA illumination standards

COMPLIANCE

- 5-year warranty on housing and electronics. Battery is prorated

WEEU

WATERPROOF EXIT/EM COMBO



DIMENSIONS

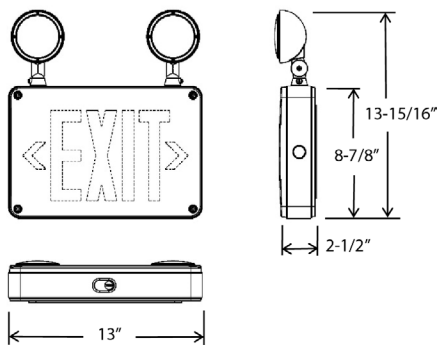

ORDERING GUIDE

MODEL	MOUNTING	LETTER COLOR	HOUSING COLOR	OPTION
WEEU Weatherproof Combo	U Universal	R Red G Green	W White B Black	SD Self Diagnostics REM Remote Capable C Cold Weather (Operating temperature range: -25-40° C)

Notes:
1. Single face only