



INV-S1-5/40

# ASTRALITE INVERTER

## SINGLE PHASE 0.5 - 4.0KW

**WARRANTY**

- 1-year full warranty on system electronics
- 1-year full warranty with 9-year pro-rated warranty on battery
- Extended warranty available
- Maintenance contracts available
- 1-year on-set warranty labor if the inverter system is commissioned by Astralite and is performed by an Astralite authorized service agent

**CABINETS**

- Space saving, small footprint with modular designs allows for flexible installation
- Standard free standing enclosure with power coat finish
- Optional NEMA – 3r, 4x, or 12 Cabinets with forced air cooling for maximum reliability

**STANDARDS**

- Listed to UL924, meets NFPA 101, NFPA 70, NEC and OSHA standards

**EFFICIENCY**

- Overall system efficiency exceeds 96%

**OPTIONS**

- Available with various options to interact with central lighting control or dimming systems.

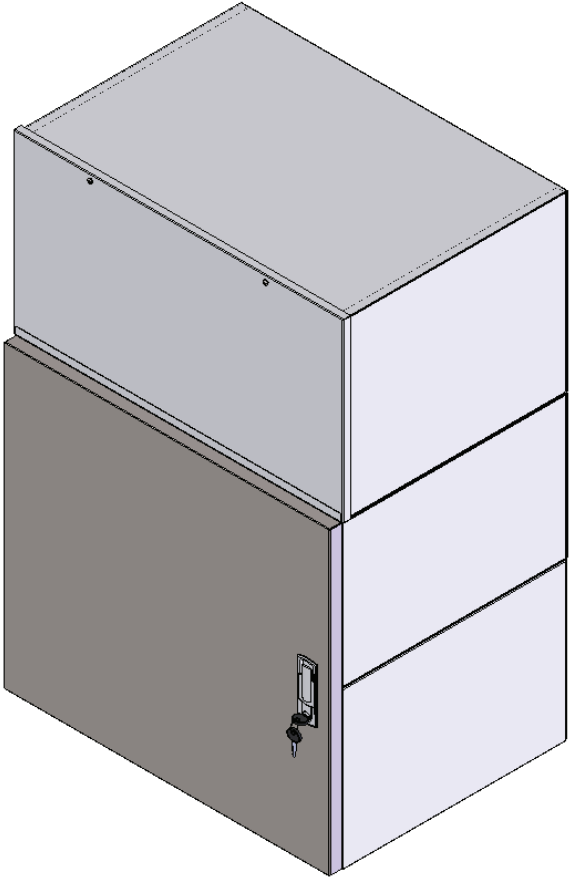

**APPLICATIONS**

- Central lighting inverter with full light output.
- Operates fluorescent, compact fluorescent, incandescent, quartz, L.E.D and other lamp types

**MAINTENANCE**

- Hassle-free maintenance – the unit automatically monitors itself.

**DIAGNOSTICS AND CONTROLS**

- Advanced front panel LED display indicating unit status, battery status, load status and other metering.
- Single point of testing

**ORDERING INFORMATION:**

<b>INV-S1</b>																					
<b>FAMILY</b>	<b>POWER RATING</b>	<b>VOLTAGE</b>	<b>OPTIONS</b>																		
	<table style="margin: auto;"> <tr><td style="border-bottom: 1px solid black;">KW</td></tr> <tr><td>0.5</td></tr> <tr><td>1.2</td></tr> <tr><td>1.5</td></tr> <tr><td>2.0</td></tr> <tr><td>2.2</td></tr> <tr><td>2.4</td></tr> <tr><td>4.0*</td></tr> </table>	KW	0.5	1.2	1.5	2.0	2.2	2.4	4.0*	<table style="margin: auto;"> <tr><td style="border-bottom: 1px solid black;">Input</td><td style="border-bottom: 1px solid black;">Output</td></tr> <tr><td>120</td><td>120</td></tr> <tr><td>208</td><td>277</td></tr> <tr><td>240</td><td>120-240</td></tr> <tr><td>277</td><td>120-277</td></tr> </table>	Input	Output	120	120	208	277	240	120-240	277	120-277	<p><b>ETM120</b> - 120V Environmental control module / qty</p> <p><b>ETM277</b> - 277V Environmental control module / qty</p> <p><b>SPC</b> - Specialized enclosure*</p> <p><b>NF</b> - Normally standby configuration</p> <p><b>OCB</b> - 20 Amps output circuit breakers / voltage / quantity</p> <p><b>SRM</b> - Seismic rated bracket</p> <p><b>STUM</b> - Onsite start-up</p> <p><b>IDB</b> - Internal dimmer bypass</p> <p><b>EMB</b> - External maintenance bypass switch</p> <p><b>EW</b> - Extended warranty</p>
KW																					
0.5																					
1.2																					
1.5																					
2.0																					
2.2																					
2.4																					
4.0*																					
Input	Output																				
120	120																				
208	277																				
240	120-240																				
277	120-277																				

\* Consult factory for more options