



CATALOG NUMBER	TYPE
PROJECT NAME	DATE

SPECIFICATIONS

FEATURES

- Extruded aluminum edgelit exit sign with reverse wording
- Designed for surface mounting
- Unit draws less than 3W

CONSTRUCTION

- Extruded aluminum trim with acrylic panel
- EXIT letters are 6" tall with 3/4" stroke; 100 ft viewing distance
- Field-selectable chevron directional indicator offers a choice of direction on-site

LAMP

- AllInGaP LEDs with a rated life of 10+ years

ELECTRONICS

- Dual-voltage input capability: 120/277V
- Low-voltage disconnect
- AC indicator light with test switch
- Brownout protection

BATTERY

- EM option comes standard with nickel-cadmium battery
- Provides a minimum of 90 minutes of illumination upon loss of power

COMPLIANCE

- Meets or exceeds UL 924, NFPA 101, NEC and OSHA illumination standards

WARRANTY

- 5-year warranty on housing and electronics. Battery is prorated

ELX-RW

REVERSE WORDING EXIT SIGN



DIMENSIONS

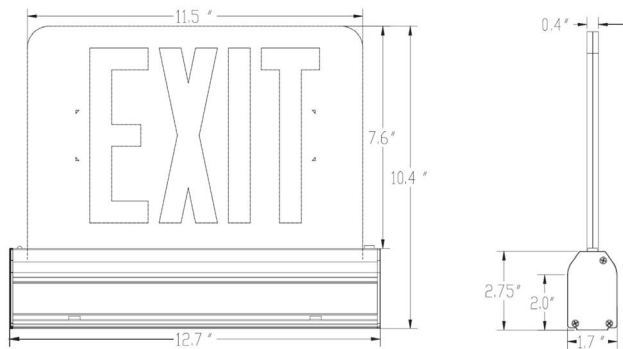

Material	Battery	Code Compliance	Dimensions
Aluminum	Nickel-cadmium	UL 924	12.7" W X 10.4" H X 1.7" D

ORDERING GUIDE

MODEL	NO. OF FACES	LETTER/BACKGROUND	TRIM FINISH	POWER CONFIGURATION	OPTIONS
ELX-RW Reverse Wording LED Exit Sign	1 Single 2 Double	RC Red on Clear RW Red on White RM Red on Mirrored GC Green on Clear GW Green on White GM Green on Mirrored	BA Brushed Aluminum WHT Powder Coated White BLK Powder Coated Black DB Dark Bronze BR Brass Type Face Plate	AC AC Only EM Battery Backup 2CKT Two Circuit Input	SW Special Wording

Notes:

1. Single face only